

PHONE BOOTH

Disassembly Guide

R O
O M



R O
O M



+1 (646) 791-3726
room.com



Ready to make a move?

We designed our booth to be flexible, so whether you're switching floors or moving into a new building, you can take the booth wherever you go. Read on for what we recommend, depending on the type of move you're planning.

If you plan on moving the booth just a little

If you need to move the booth less than 10 feet across a flat surface, you can gently push the booth using furniture pads. This will prevent you from damaging the feet and scratching the floor.

If you're moving to a new floor or building

We recommend disassembly. Follow the steps in this guide to keep your booth in good condition.

If you want professional help

Let us do the heavy lifting. Our moving service includes disassembly, pickup, delivery and reassembly in your new space. The fee varies depending on the pickup and delivery logistics. Send us a note at support@room.com and we'd be happy to give you a quote.

Step by step

We're here for you at every step of the process.
If you get stuck, send us a note at support@room.com
and we'll get through this together.

What you'll need

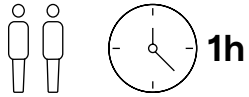

Tools

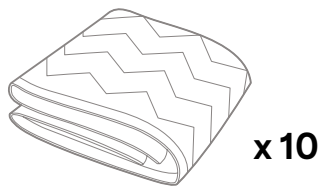
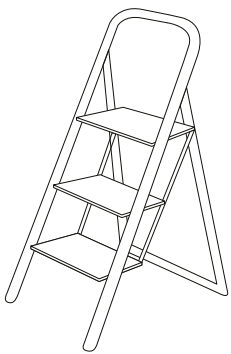

Moving blanket
(98" x 72")

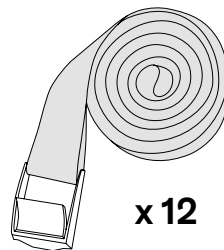

Tie-down strap
(8')

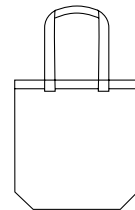

4mm

Support



support@room.com

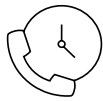

+1 (646) 791-3726

01

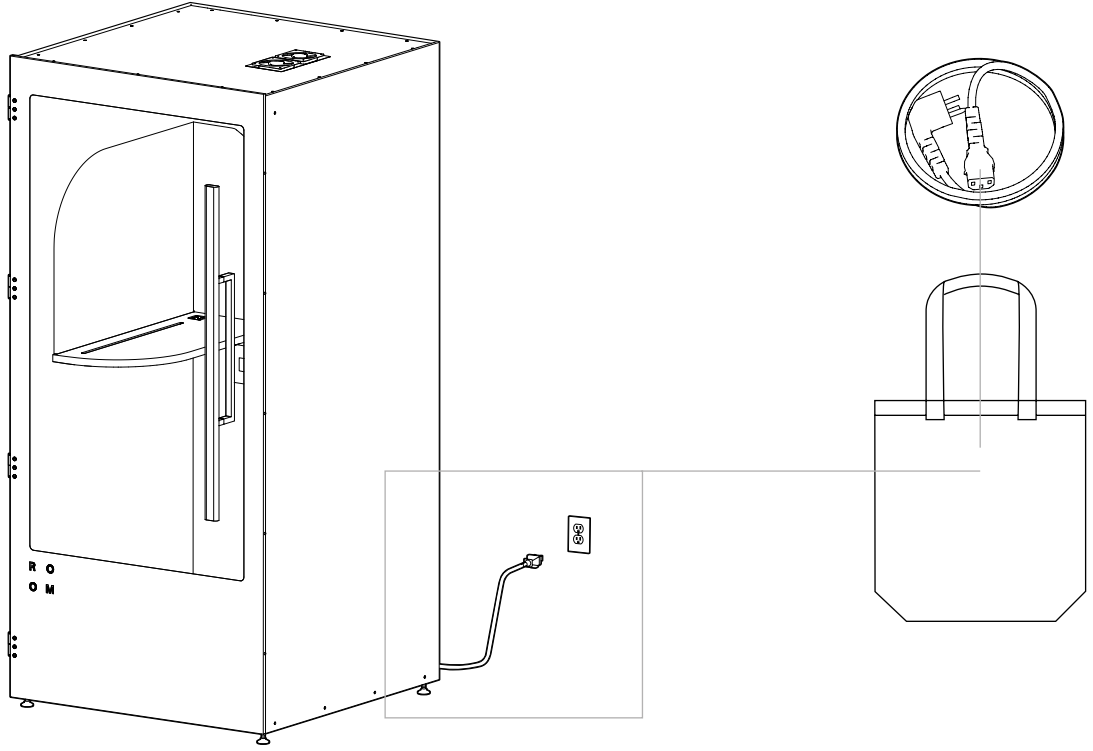

02

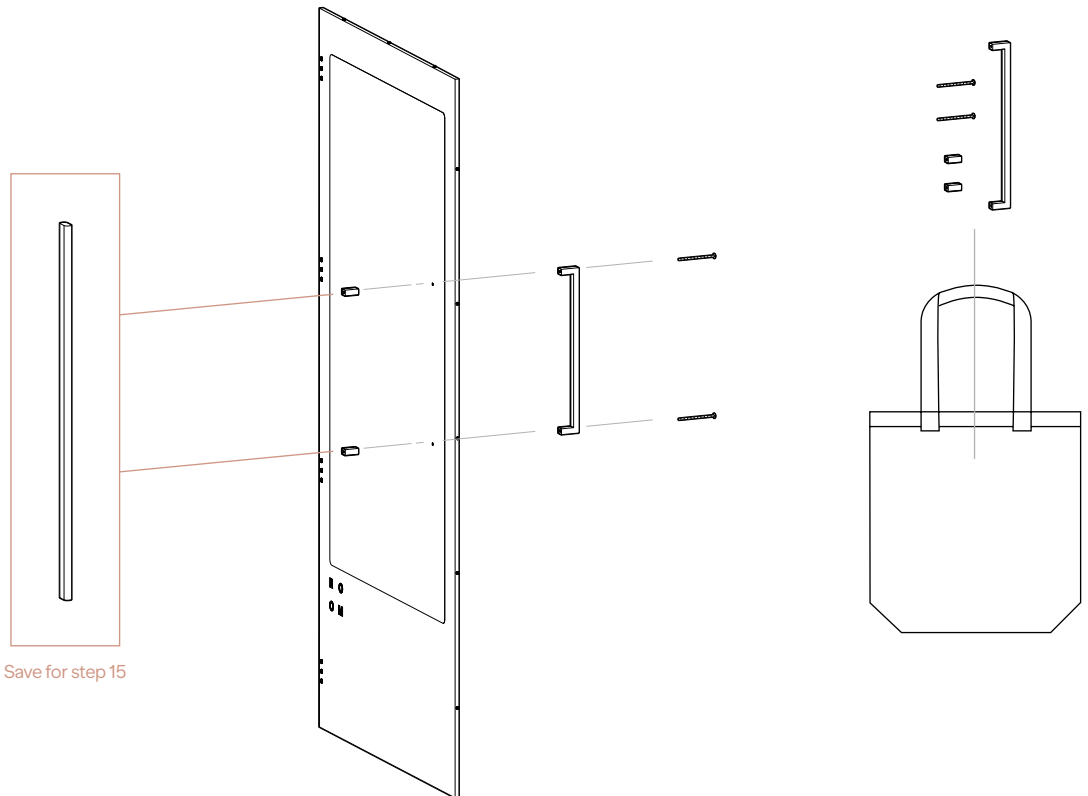

03

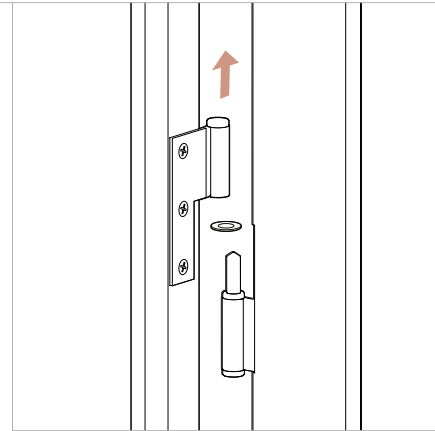
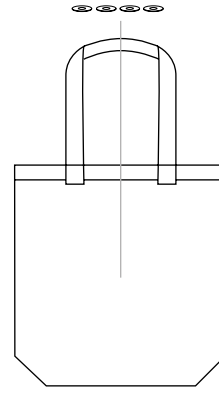
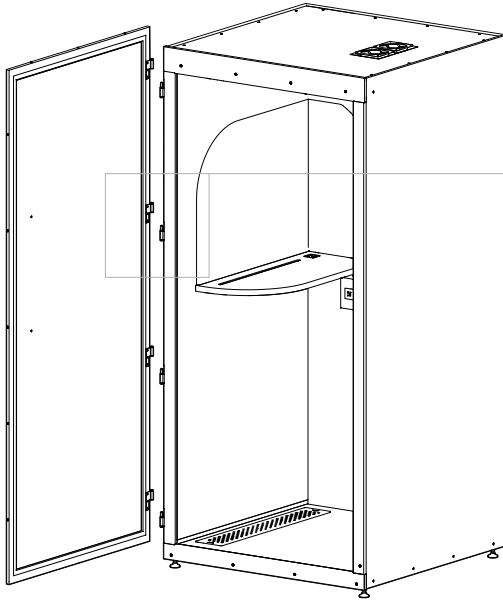

04

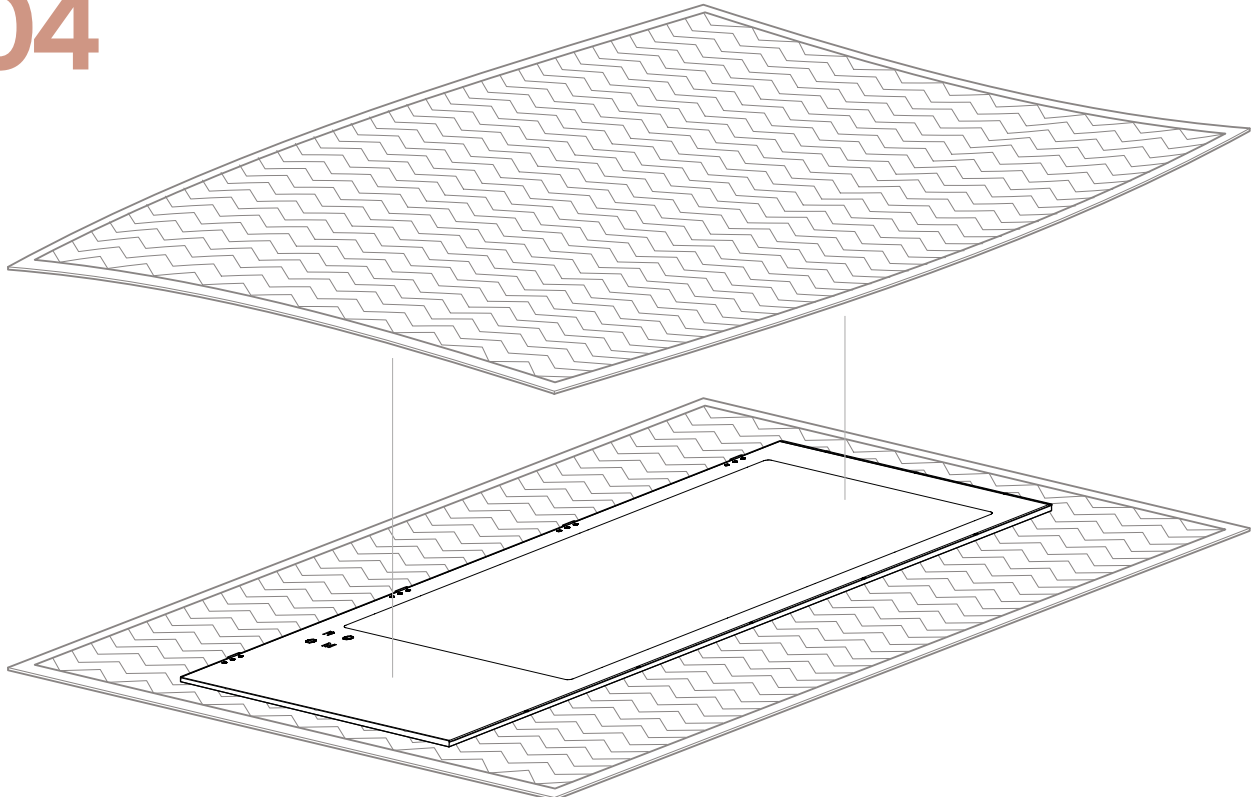

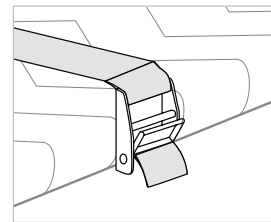
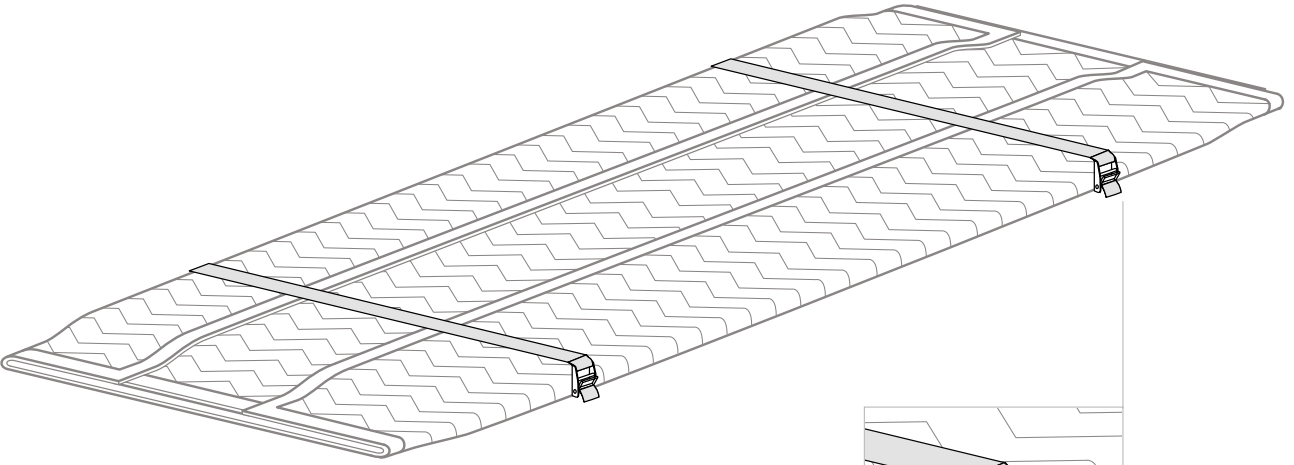
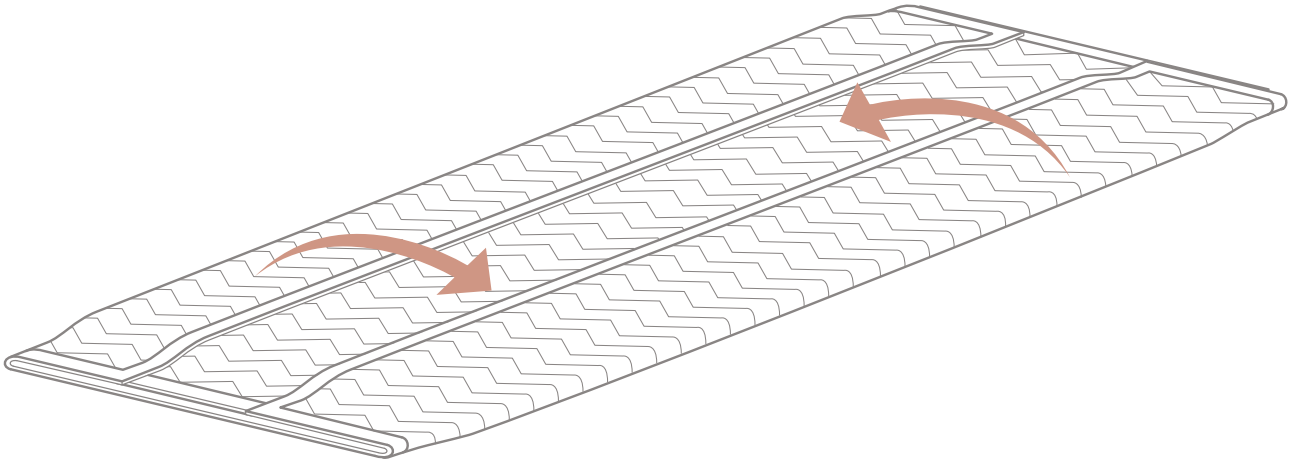

05

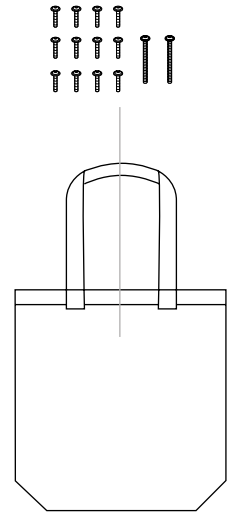
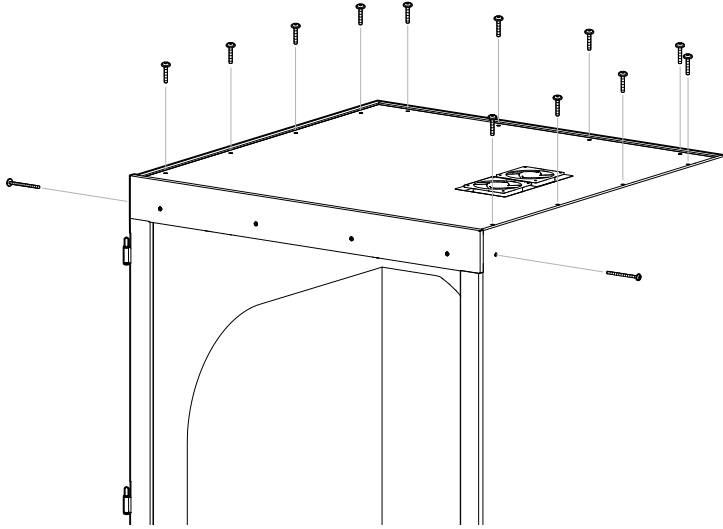

06

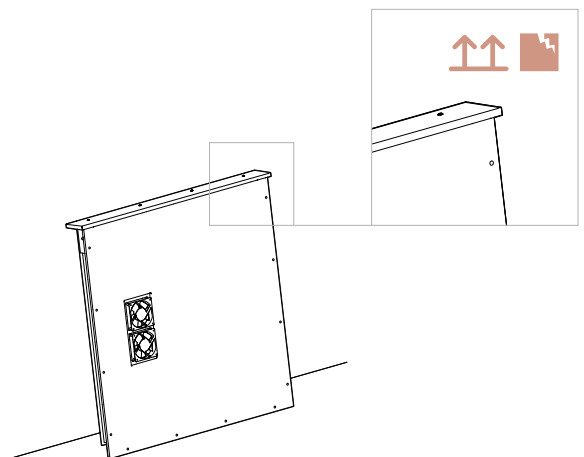
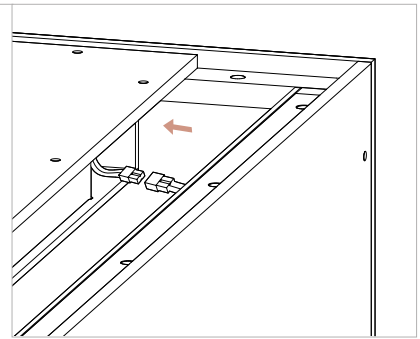
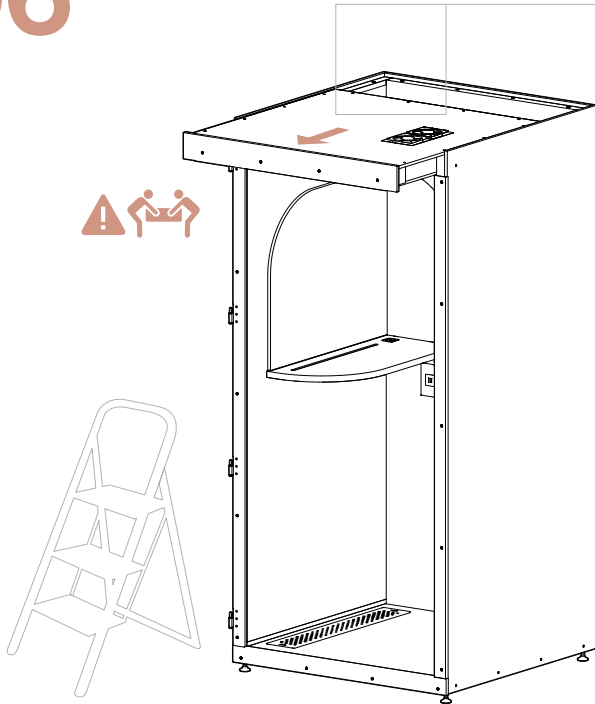

07

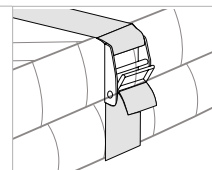
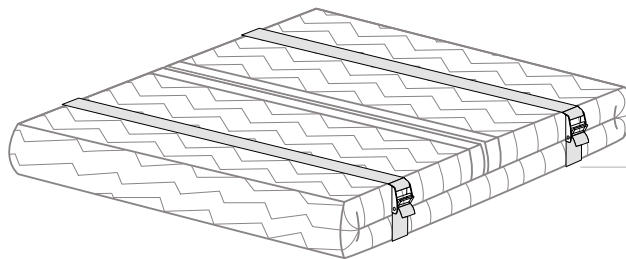
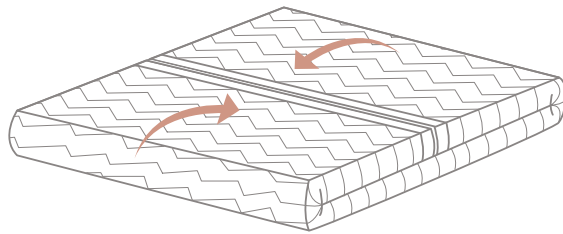
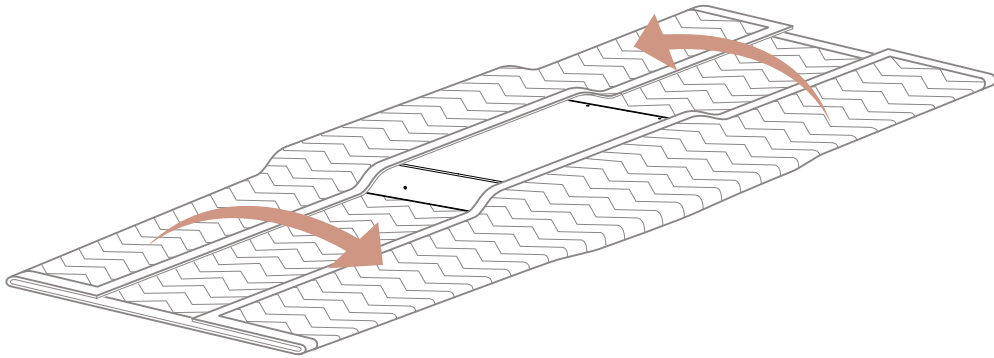
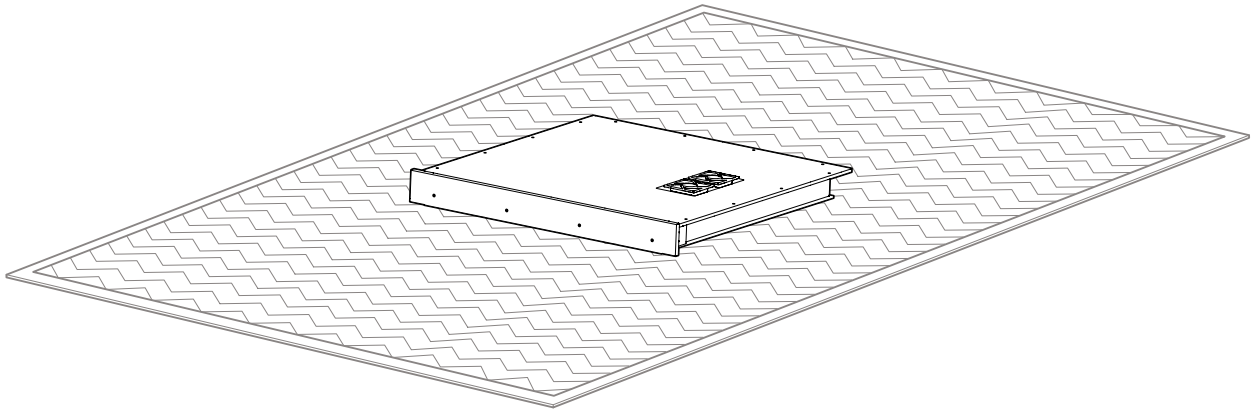

08

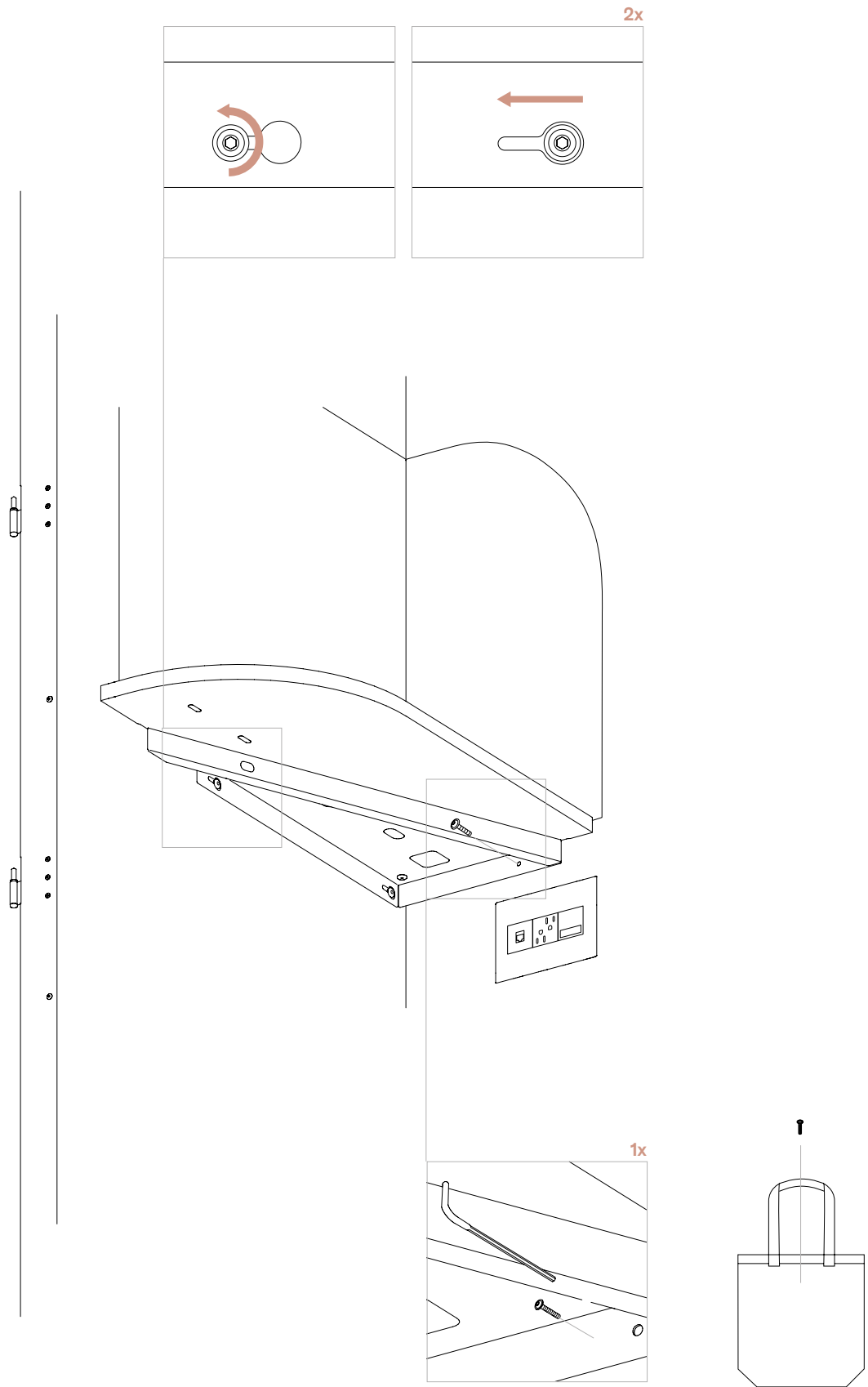

9

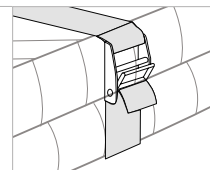
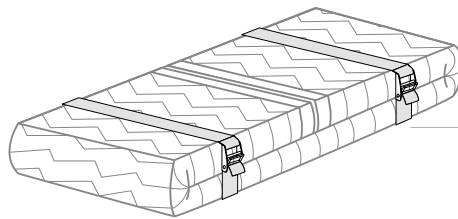
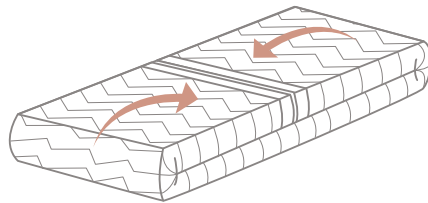
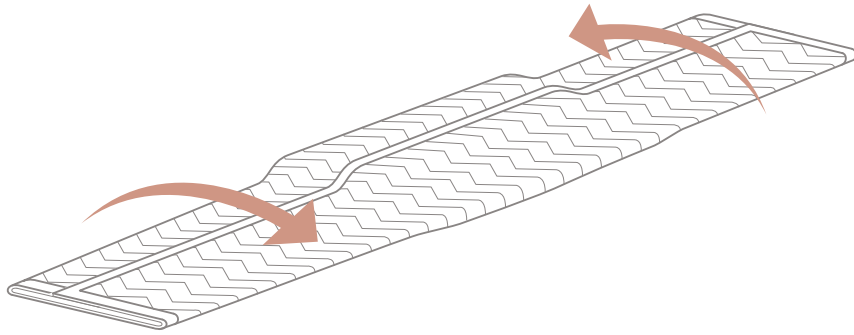
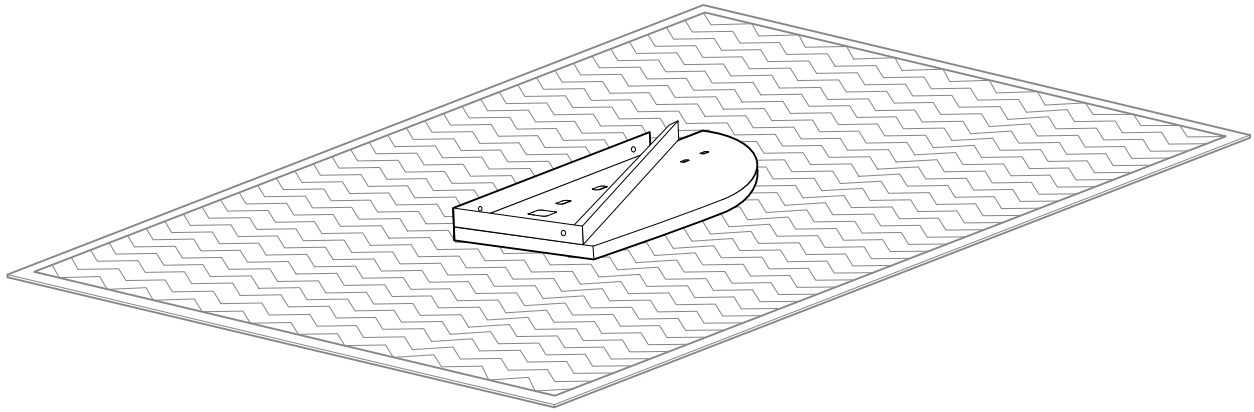

10

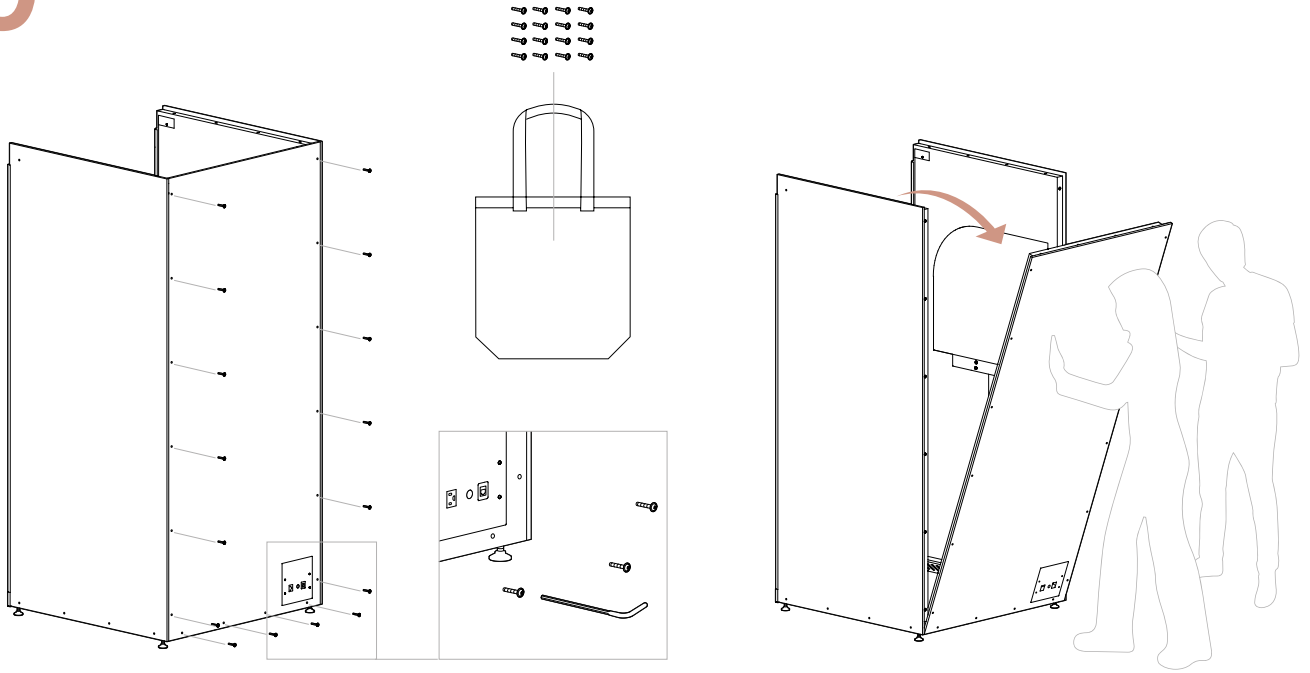

11

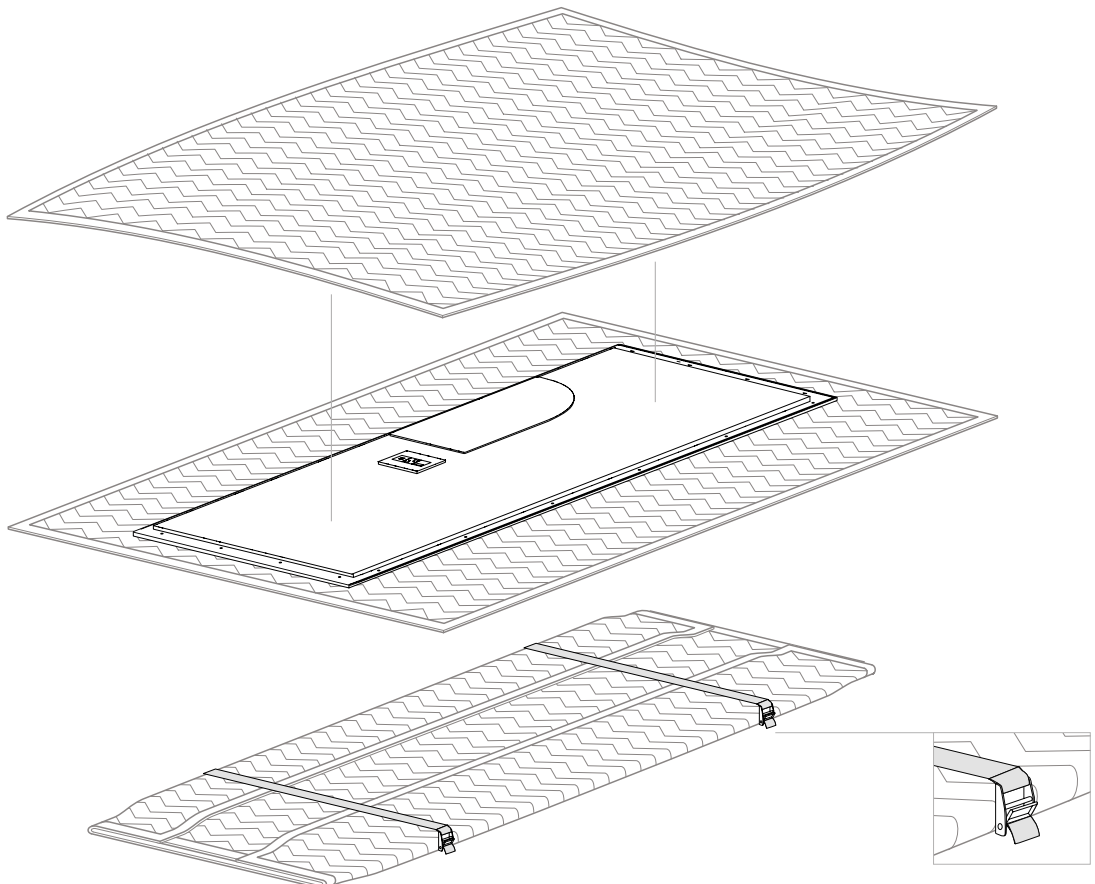

12

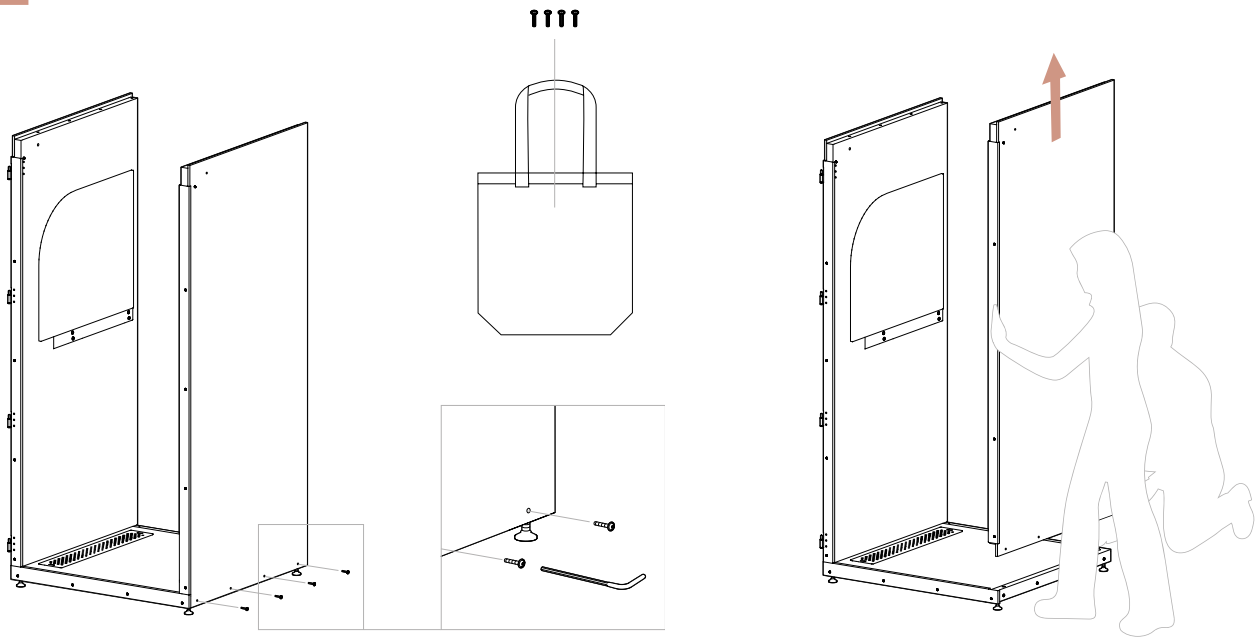

13

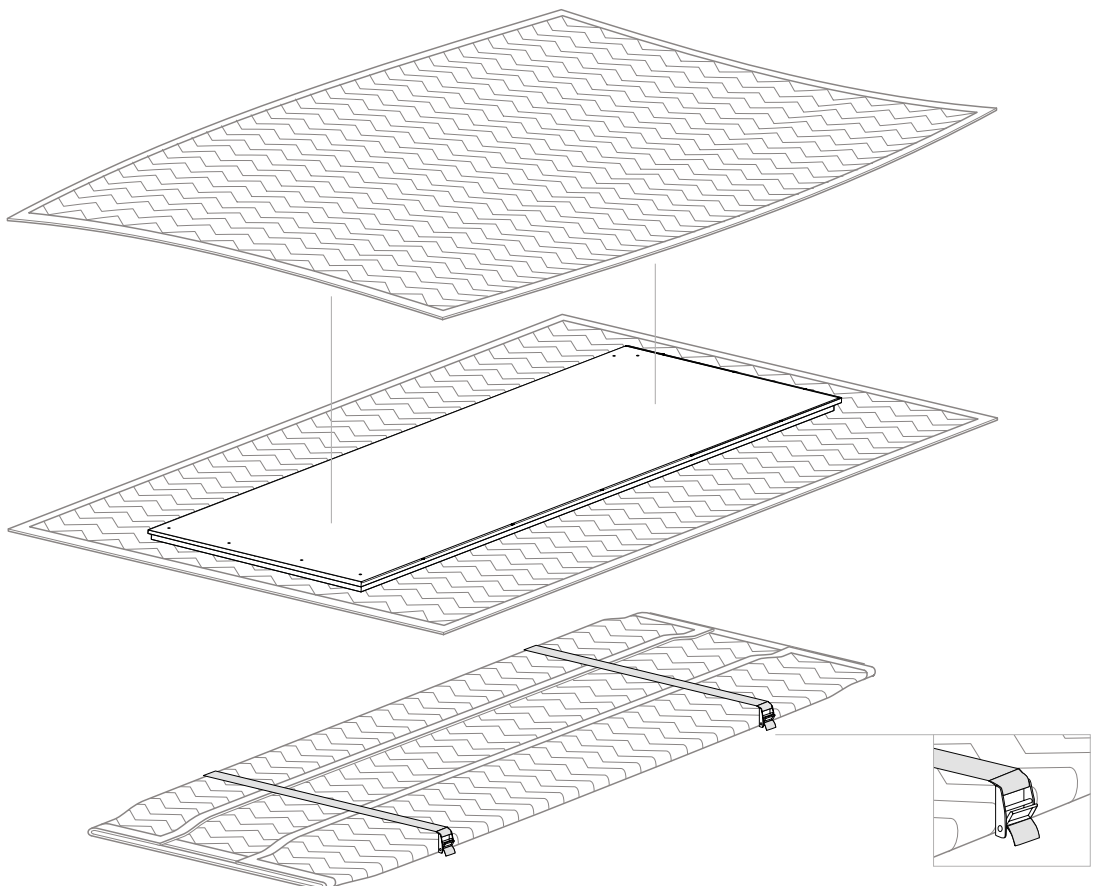

14

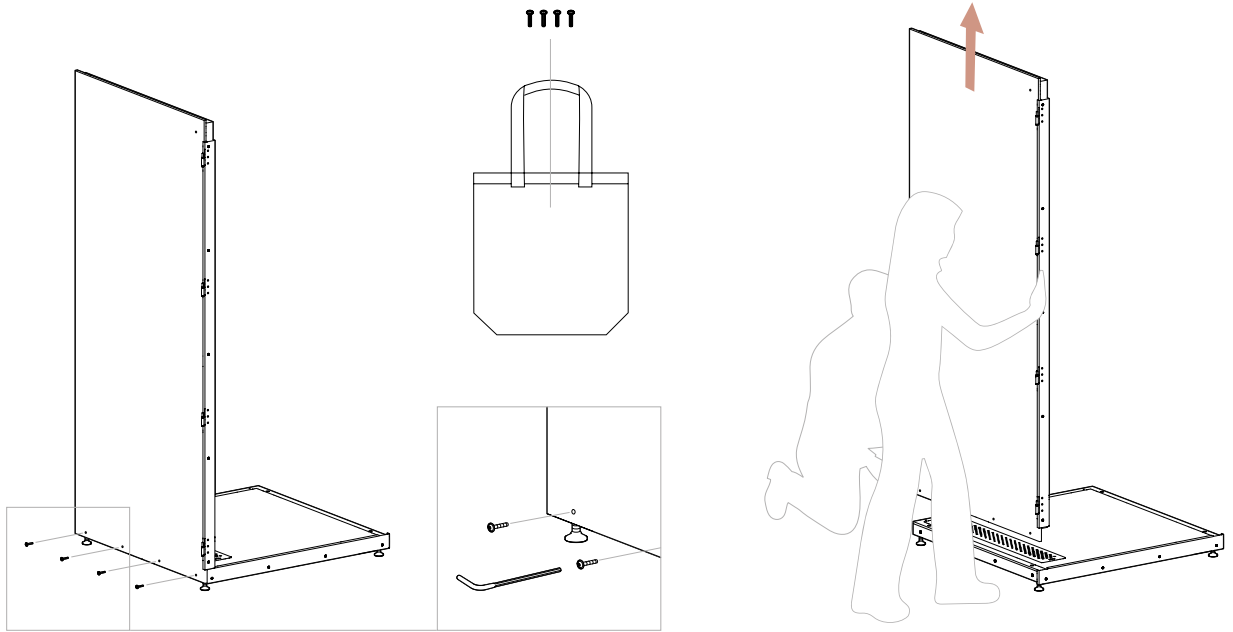

15

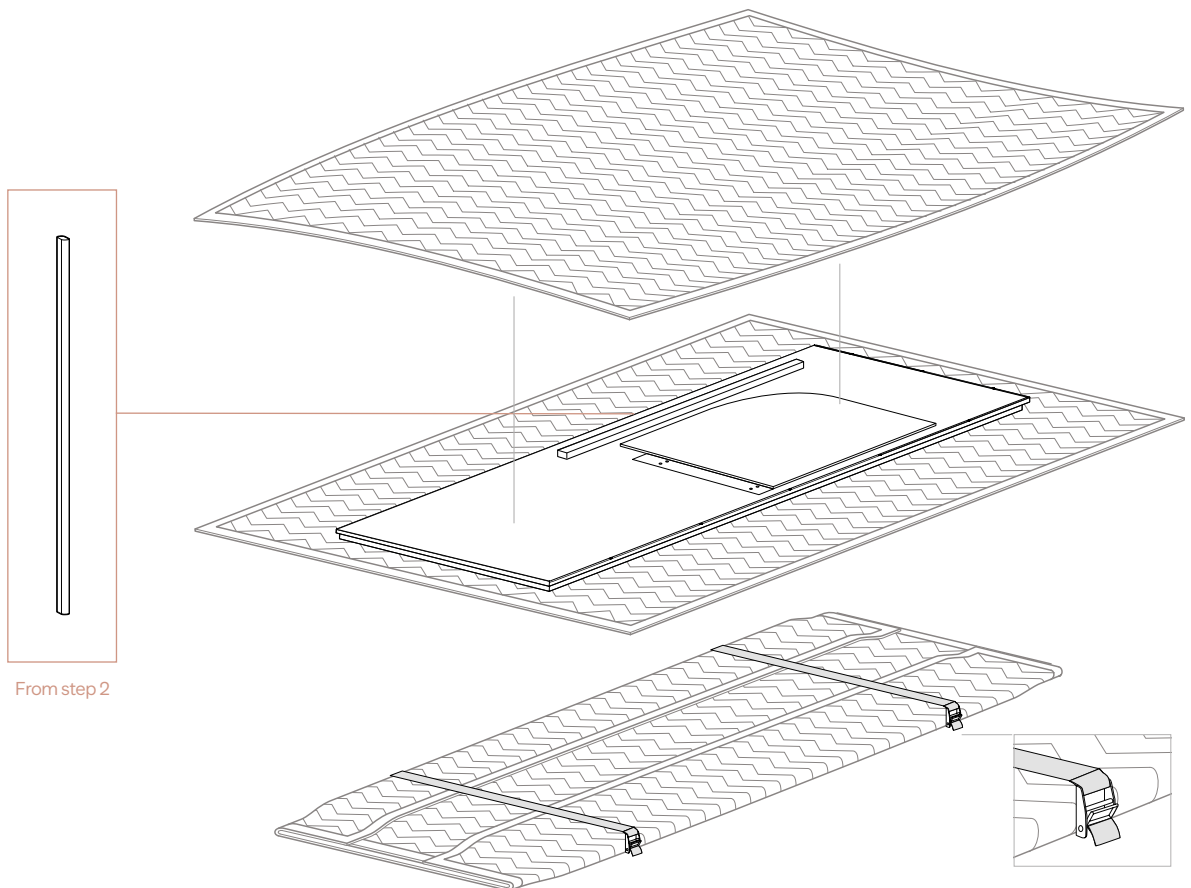

16

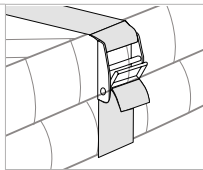
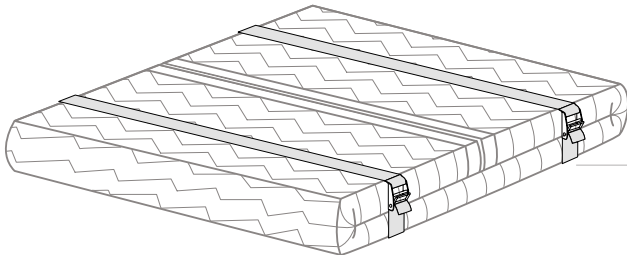
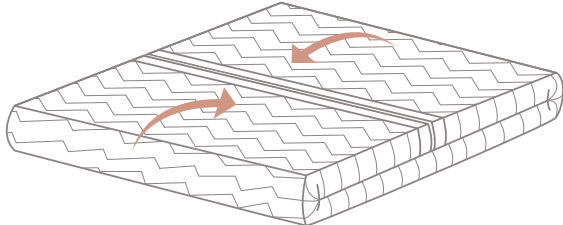
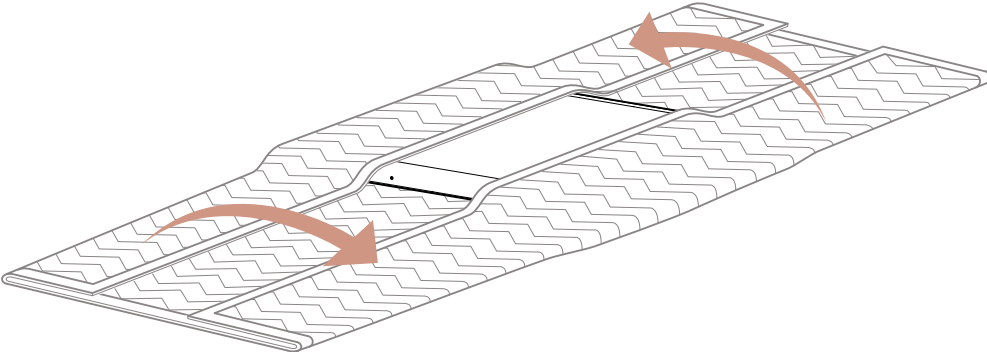
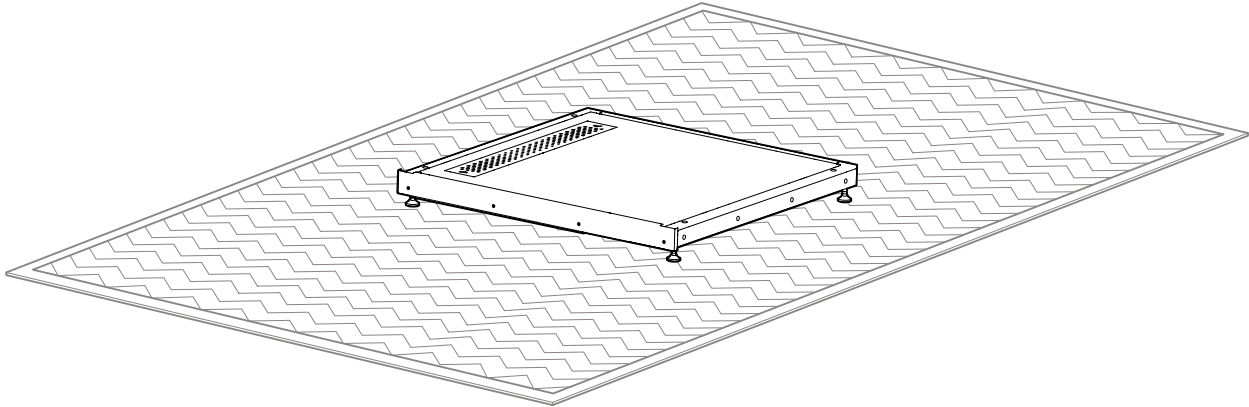



Make room for more

Your booth is ready to make some moves. Once you arrive at your new location, carefully unpack each piece and assemble the booth following our assembly manual.

A few things before you go:



Save your tools

Our booth is designed to move and grow with you. Store the tie-down straps and blankets in a safe place, so you can use them again for your next move.



Stack it the right way

Depending on the structure of your building, you may have to stack the pieces when you move out. Place the right wall at the very bottom, followed by the left wall, and then the back wall on top. Then, place the roof and ceiling side by side, followed by the door. Lastly, place the desk and desk support on top, and you're good to go.



Lost hardware

Lost a bolt along the way? Damaged a part? Don't worry, we've got you. Send us a note at support@room.com and we'd be happy to help.

